

Wrapid Tape™

HCA, HCO, HCC

Primer-less, Crosslinked, Corrosion Protection Tape.

Product Description

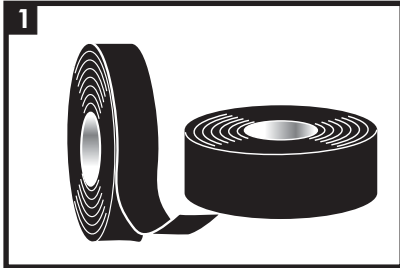

Canusa Wrapid Tape™ is supplied in 15 m length bulk rolls, in several widths to suit the project diameter.

Storage & Safety Guidelines

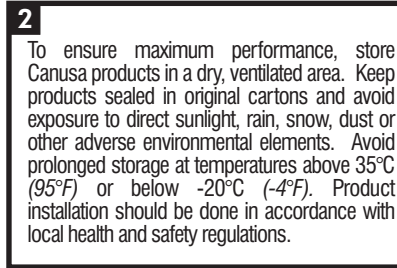

To ensure maximum performance, store Canusa products in a dry, ventilated area. Keep products sealed in original cartons and avoid exposure to direct sunlight, rain, snow, dust or other adverse environmental elements. Avoid prolonged storage at temperatures above 35°C (95°F) or below -20°C (-4°F). Product installation should be done in accordance with local health and safety regulations.

These installation instructions are intended as a guide for standard products. Consult your Canusa representative for specific projects or unique applications.

Equipment List

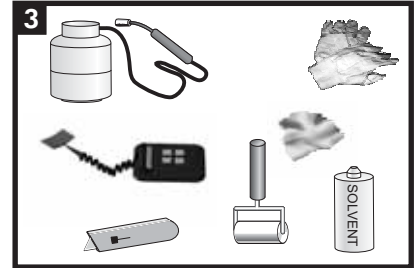

Propane tank, hose, torch & regulator
Appropriate tools for surface abrasion
Knife, roller, rags & approved solvent cleanser
Digital thermometer with suitable probe
Standard safety equipment; gloves, goggles, hard hat, etc.

Flame Intensity & Torch Size

<p>4</p> <p>Pipe O.D. ≤450mm (18")</p> <p>Use <i>moderate</i> flame intensity for pre-heating and shrinking.</p>	<p>Pipe O.D. >450mm (18")</p> <p>Use <i>moderate to high</i> flame intensity for pre-heating and shrinking.</p>
<p>Minimum Torch Size: 150,000 BTU/hr.</p>	<p>Minimum Torch Size: 300,000 BTU/hr.</p>

Surface Preparation

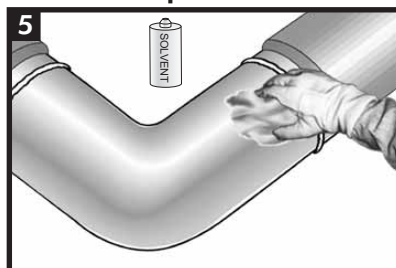

Ensure that the PE coating edges are beveled to 30°. Clean exposed steel and adjacent pipe coating with a solvent cleanser to remove the presence of oil, grease, and other contaminants.

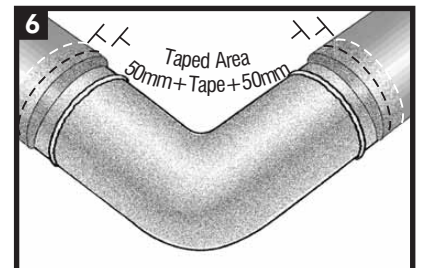

Ensure that the pipe is dry before cleaning. Prepare the steel joint area to a minimum of Si3 /SP3. Lightly abrade the pipe coating adjacent to the weld area to a distance of 50mm (2") beyond each end of the area to be taped.

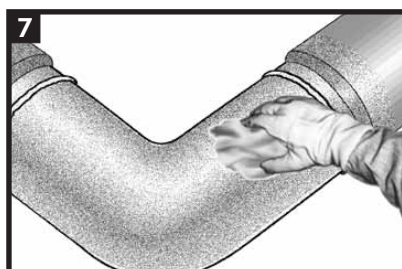

Wipe clean or air blast the steel and pipe coating to remove foreign contaminants.

Pre-Heat

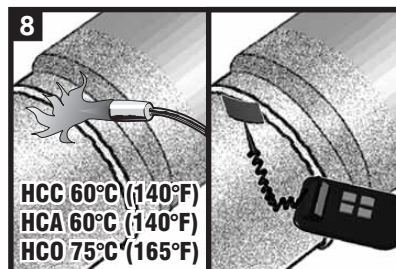

HCC 60°C (140°F)
HCA 60°C (140°F)
HCO 75°C (165°F)

Pre-Heat the joint area to the minimum required temperature HCA: 60°C (140°F) HCO: 75°C (165°F) HCC: 60°C (140°F). Using a temperature measuring device, ensure that the correct temperature is reached on the steel and at least 50mm (2") on each side of the tape.

Tape Installation

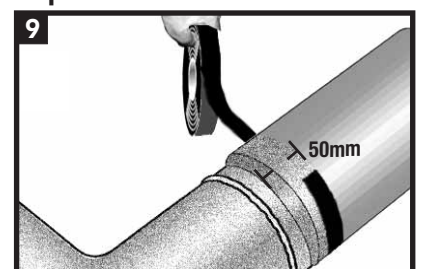

Starting at least 50mm (2") onto the pipe coating, begin wrapping the tape around the joint, ensuring a minimum 50% spiral overlap. Ensure that the powdered tape side is placed onto the pipe. Remove any plastic release liners as the product is wrapped.

Wrapid Tape™ - HCA, HCO, HCC

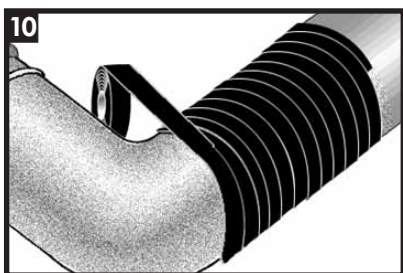

Continue wrapping the pipe ensuring a minimum 50% overlap.

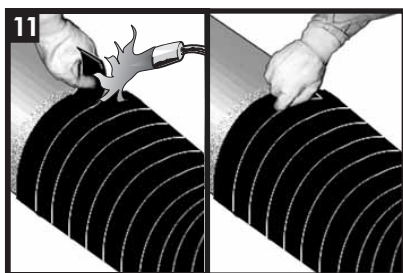

Warm the tape end and press down firmly. A hold-down tape can be used to secure the tape end.

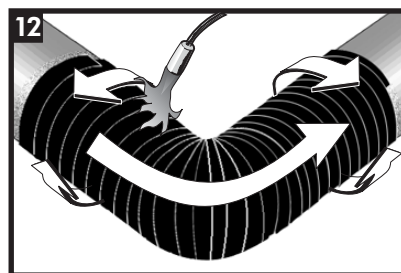

Using a torch, begin at the edge of the tape and heat circumferentially around the joint, working back to the other edge.

Inspection

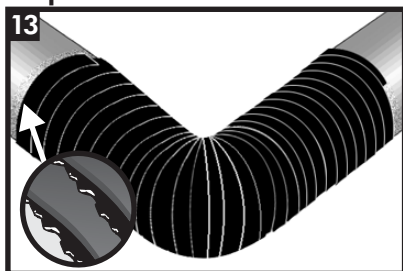

Visually inspect the taped joint for the following:

- Tape is in full contact with the joint and extends 50mm (2") onto the pipe coating.
- Adhesive flows at the tape edges.
- No cracks or holes in the tape.

Backfilling Guidelines

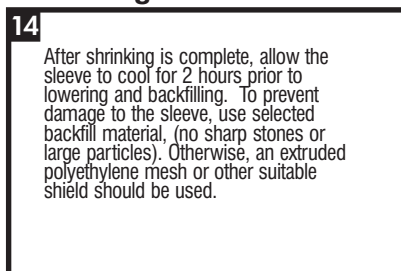

After shrinking is complete, allow the sleeve to cool for 2 hours prior to lowering and backfilling. To prevent damage to the sleeve, use selected backfill material, (no sharp stones or large particles). Otherwise, an extruded polyethylene mesh or other suitable shield should be used.

Tape Usage Guide

Nominal Pipe Diameter	Recommended Tape Width		Length of Tape Required	
			3D Bend	5D Bend
	DN	inches	m	feet
25	1	50 mm	2.8 m	9.3 feet
40	1.5	50 mm	4.0 m	13.2 feet
50	2	50 mm	5.2 m	17 feet
80	3	50 mm	8.5 m	28 feet
100	4	50 mm	12.3 m	40 feet
125	5	75 mm	11.1 m	36.4 feet
150	6	75 mm	14.3 m	46.9 feet
200	8	100 mm	16.3 m	53.4 feet
250	10	100 mm	23.1 m	75.8 feet
300	12	100 mm	30.4 m	99.8 feet
>300	>12	150 mm	see formula at right	

The table at left shows the typical usage for 3D and 5D bends, assuming a line coating cutback of 150 mm (6") and a 50 mm (2") overlap onto the pipe coating.

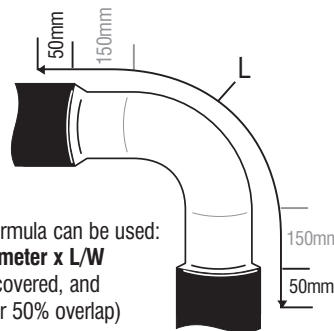

For other sizes, the following formula can be used:

$$\text{Length of tape} = \pi \times \text{pipe diameter} \times L/W$$

where L=length of area to be covered, and

$$W = \frac{1}{2} \text{ of tape width (for 50\% overlap)}$$



A SHAWCOR COMPANY

Canada

CANUSA-CPS
a division of SHAWCOR LTD.
25 Bethridge Road
Rexdale, Ontario
M9W 1M7,
Canada
Tel: +1 (416) 743-7111
Fax: +1 (416) 743-5927

U.S.A./Latin America

CANUSA-CPS
a division of SHAWCOR INC.
2408 Timberloch Place
Building C-8
The Woodlands, Texas
77380, U.S.A.
Tel: +1 (281) 367-8866
Fax: +1 (281) 367-4304

Europe/Middle East

CANUSA-CPS
a division of Canusa Systems Ltd.
Unit 3, Sterling Park
Gatwick Road
Crawley, West Sussex
England RH10 9QT
Tel: +44 (1293) 541254
Fax: +44 (1293) 541777

www.canusacps.com

Asia/Pacific

CANUSA-CPS
a division of SHAWCOR LTD.
#05-31, Blk 52, Frontier
Ubi Avenue 3
Singapore
408867
Tel: +65-6749-8918
Fax: +65-6749-8919

Canusa warrants that the product conforms to its chemical and physical description and is appropriate for the use stated on the installation guide when used in compliance with Canusa's written instructions. Since many installation factors are beyond our control, the user shall determine the suitability of the products for the intended use and assume all risks and liabilities in connection therewith. Canusa's liability is stated in the standard terms and conditions of sale. Canusa makes no other warranty either expressed or implied. All information contained in this installation guide is to be used as a guide and is subject to change without notice. This installation guide supersedes all previous installation guides on this product. E&OE