

Canusa SuperStop - CSS

End cap to seal pre-insulated pipe ends

Canusa-CPS is a leading manufacturer of specialty pipeline coatings which, for over 30 years, have been used for sealing and corrosion protection of pipeline joints and other substrates. Canusa high performance products are manufactured to the highest quality standards and are available in a number of configurations to accommodate your specific project applications.

Product Description

The Canusa SuperStop - CSS is a heat shrinkable, end cap for pre-insulated pipes (example: district heating pipes). The CSS is made from a specially formulated crosslinked polymer combined with a high temperature adhesive providing a high quality, reliable system for the sealing protection of pre-insulated pipes.

Features & Benefits

Watertight Seal

The Canusa SuperStop - CSS is designed to provide a watertight seal and prevent water access to the exposed insulation at the weld joint area. Upon application of heat, the CSS shrinks to conform to the profile of the insulated pipe, while the adhesive simultaneously "melts" to bond to the jacket casing and the service pipe. To ensure overall protection of the insulating foam, CSS should be used on both pipe ends.

Insulation Protection

The Canusa SuperStop - CSS can be factory-installed on the pre-insulated pipe. Once installed, the CSS protects the insulation during transportation and storage. During service, the CSS prevents water ingress into the insulation in the event of leakage at the joint. If there is a leakage within a pipe length, the CSS limits the insulation degradation to one pipe length. This can greatly reduce repair costs.

Large Size Range



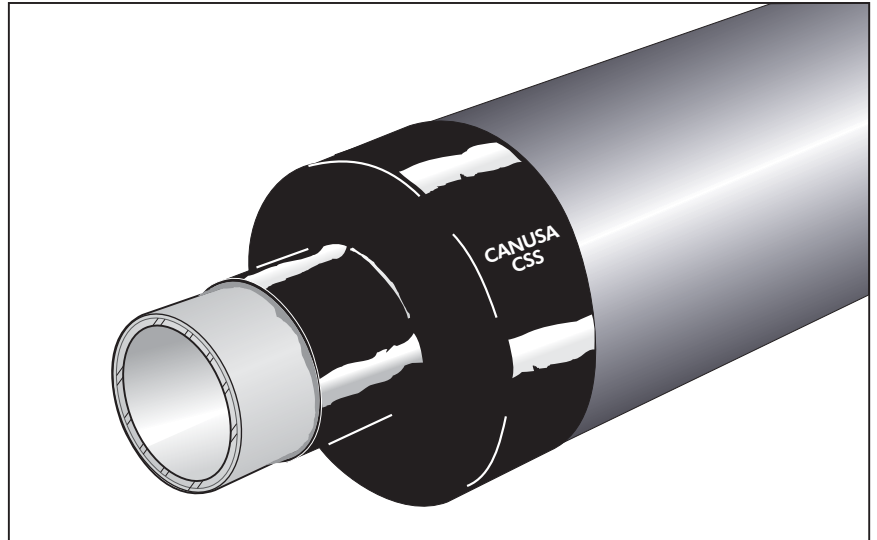

The Canusa SuperStop - CSS is available in a full range of sizes to fit most pipe/casing combinations. Since the CSS is heat shrinkable, one size can be used to cover several casing pipe/service pipe combinations.

Easy Installation



The Canusa SuperStop - CSS is quick and easy to install. Upon application of heat the product quickly conforms to cover the pipe ends. The CSS comes with pre-applied adhesive which reduces the installation time.



Applications

-  **Pre-Insulated Pipes**
-  **Oil & Gas**
-  **Water Pipelines**
-  **End Seal**
-  **High Temp**

Configurations

-  **Moulded Shape**
-  **High Shrink**

Pipe Sizes

-  **PE 63 - PE 630**

Temperature Range

-  **up to 135°C (275°F)**

The product selection guide shown below is intended as a guide for standard products. Consult your Canusa representative for specific projects or unique applications.

Canusa SuperStop - CSS

		Jacket Pipe O.D. (mm)																							
		63	75	90	110	125	140	160	180	200	225	250	266	280	297	315	326	334	355	400	450	500	630		
Service Pipe O.D. (mm)	12																								
	15																								
	17	10																							
	21	10		20																					
	27	10		20		30																			
	34	10		20		30		40																	
	42	10		20		30		40		50															
	48	10		20		30		40		50		60													
	54	10		20		30		40		50		60		70											
	60	10		20		30		40		50		60		70		80									
	76	10		20		30		40		50		60		70		80		90							
	89	10		20		30		40		50		60		70		80		90		100					
	108	10		20		30		40		50		60		70		80		90		100		110			
	114	10		20		30		40		50		60		70		80		90		100		110			
	133	10		20		30		40		50		60		70		80		90		100		110			
	139	10		20		30		40		50		60		70		80		90		100		110			
	159	10		20		30		40		50		60		70		80		90		100		110			
	168	10		20		30		40		50		60		70		80		90		100		110			
	193	10		20		30		40		50		60		70		80		90		100		110			
	219	10		20		30		40		50		60		70		80		90		100		110			
245	10		20		30		40		50		60		70		80		90		100		110				
273	10		20		30		40		50		60		70		80		90		100		110				
324	10		20		30		40		50		60		70		80		90		100		110				
355	10		20		30		40		50		60		70		80		90		100		110				
406	10		20		30		40		50		60		70		80		90		100		110				
450	10		20		30		40		50		60		70		80		90		100		110				
500	10		20		30		40		50		60		70		80		90		100		110				
																				130		140		150	

NEW SIZE

Typical Product Properties

	Test Standard	Unit	Typical Result		Test Standard	Unit	Typical Result		
Sealant	Peel Strength @ 23°C 100mm/min	DIN 30672	N/cm	14	End Cap	Tensile Strength @ 23°C, 50mm/min	ASTM D638	MPa	22
		Lap Shear Strength @ 23°C 10mm/min	DIN 30672	N/cm ²		17	Tensile Elongation @ 23°C, 50mm/min	ASTM D638	%
						Thermal Aging - Elongation @ 150°C, 7 days	ASTM D638	%	375
						Low Temperature Flexibility 25mm mandrel	ASTM D3111	°C	-70
					Water Absorption @ 23°C, 24 hours	ASTM D570	%	< 0.10	

How to Order

CSS-XX	Standard Options		CSS Size (mm)		Supplied (mm)		Recovered (mm)		Length (mm)		Thickness (mm)		Adhesive Width (mm)
	Size	see product selection guide	A	B	A	B	A	B	C	D	E	F	
Product Designation	CSS- Canusa SuperStop		10	30	105	10	47	40	80	2.5	2.5	30	
Ordering & Dimensional Info			20	30	140	15	75	50	75	2.5	2.5	30	
			30	40	105	24	75	40	75	2.5	2.5	30	
	40	55	135	24	75	40	75	2.5	2.5	30			
	50	60	148	24	75	40	75	2.5	2.5	30			
	60	60	175	30	135	50	85	2.5	2.5	30			
	70	90	150	40	90	55	75	2.5	2.5	30			
	80	95	195	50	130	45	65	2.5	2.5	30			
	90	145	240	68	145	60	75	2.5	2.5	30			
	100	150	270	68	145	60	75	2.5	2.5	30			
	110	180	295	120	220	40	100	2.5	2.5	30			
	120	255	360	120	220	40	100	2.5	2.5	30			
	130	280	420	200	340	40	100	2.5	2.5	30			
	140	415	540	200	340	40	100	2.5	2.5	30			
	150	530	650	260	360	55	85	2.5	2.5	30			

All dimensions are nominal in mm



A SHAWCOR COMPANY

Canada

CANUSA-CPS
a division of SHAWCOR LTD.
25 Bethridge Road
Rexdale, Ontario
M9W 1M7,
Canada
Tel: +1 (416) 743-7111
Fax: +1 (416) 743-5927

U.S./Latin America

CANUSA-CPS
a division of SHAWCOR INC.
2408 Timberloch Place
Building C-8
The Woodlands, Texas
77380, U.S.A.
Tel: +1 (281) 367-8866
Fax: +1 (281) 367-4304

Europe/Middle East

CANUSA-CPS
a division of Canusa Systems Ltd.
Unit 3, Sterling Park
Gatwick Road
Crawley, West Sussex
England RH10 9QT
Tel: +44 (1293) 541254
Fax: +44 (1293) 541777

Asia/Pacific

CANUSA-CPS
a division of SHAWCOR LTD.
#05-31, Blk 52, Frontier
Ubi Avenue 3
Singapore
408867
Tel: +65-6749-8918
Fax: +65-6749-8919

Canusa warrants that the product conforms to its chemical and physical description and is appropriate for the use stated on the installation guide when used in compliance with Canusa's written instructions. Since many installation factors are beyond our control, the user shall determine the suitability of the products for the intended use and assume all risks and liabilities in connection therewith. Canusa's liability is stated in the standard terms and conditions of sale. Canusa makes no other warranty either expressed or implied. All information contained in this installation guide is to be used as a guide and is subject to change without notice. This installation guide supersedes all previous installation guides on this product. E&OE