

High Shrink Sleeves

Sleeves for corrosion protection of high profile joints

Canusa-CPS is a leading manufacturer of specialty pipeline coatings which, for over 30 years, have been used for sealing and corrosion protection of pipeline joints and other substrates. Canusa high performance products are manufactured to the highest quality standards and are available in a number of configurations to accommodate your specific project applications.

Product Description

Canusa High Shrink Sleeves are superior performance heat shrinkable products designed for corrosion protection of flanges, casings, bell and spigot joints and other high profile couplings. High Shrink Sleeves consist of a crosslinked polyolefin backing, coated with a protective heat sensitive adhesive which effectively bonds to steel substrates and common pipeline coatings including polyethylene and fusion bonded epoxy.

Features & Benefits

Flexible & Reliable Installation

High Shrink products are available in three different configurations for flexibility of installation.

I)The patented Wrapid Sleeve™ (K) incorporates a one-piece pre-attached closure strip that has been factory applied resulting in quick and reliable field installation.

II)The CanusaWrap™ (W) configuration is supplied in a bulk roll, with separate closure seals, providing just-in-time customized lengths. This flexibility results in reduced inventories and cost savings on the job site.

III)The CanusaTube™ (P) consists of a unique tubular configuration that has been factory constructed, resulting in quick and reliable field installation.

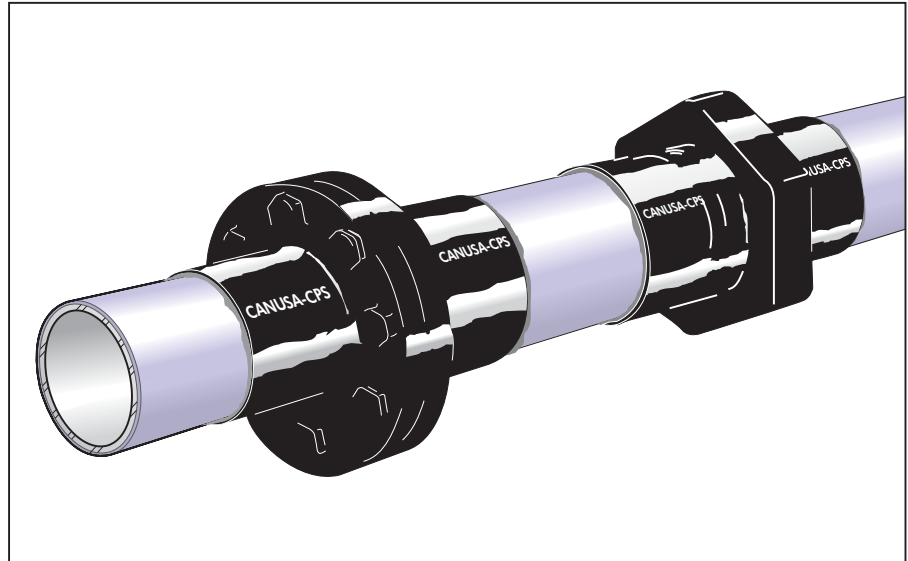

Long-Term Corrosion Protection

Once installed, the High Shrink Sleeve products have excellent structural integrity, and provide the substrate with durable protection against mechanical and chemical attack. The high performance crosslinked backing provides superior abrasion resistance and can be engineered for regular or high stress environments. In combination with Canusa's high performance adhesives, the High Shrink Sleeve provides excellent resistance to cathodic disbondment resulting in effective long term corrosion protection.

Assured Performance

The High Shrink products meet and exceed the requirements of the DIN 30 672 standard for gas and water, and have been fully tested and approved by DVGW (German Gas and Water Authority).

Applications

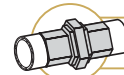

Couplings

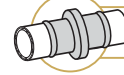

Flanges

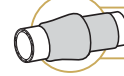

Tyton Joints



Step-Down Joints

Configurations



Wrapid Sleeve™



CanusaWrap™



CanusaTube™



High Shrink

Temperature Range



Up to 50°C (122°F)

Approvals



DIN 30672

High Shrink Sleeves

Product Selection Guide P - CanusaTube™, K - Wrapid Sleeve™, W - CanusaWrap™

Pipe Diameter	DN 25	DN 32/40	DN 50	DN 65	DN 80	DN 100	DN 125	DN 150	DN 200	DN 250	DN 300	DN 400	DN 500	
	1"	1½"	2"	2.5"	3"	4"	5"	6"	8"	10"	12"	16"	20"	
Type of Joint														
Coupling	PMA 70/25, 50/20	PMA 90/30	PMA 120/40	PMA 120/40	PMA 170/80	PMA 200/100	PMA 255/130	PMA 255/130	PMA 425/210	WLOX 1500 mm	WLOX 1700 mm	WLOX 1950 mm	WLOX 2250 mm	
Welded Joint	PMA 40/15, 50/20	PMA 70/25	PMA 90/30	PMA 90/30	PMA 120/40	PMA 170/80	PMA 200/100	Use PLA Standard Shrink Sleeves Please refer to CanusaTube™ - PLA data sheet					--	--
Flange DIN 2633 PN16		--	KLOX 185/65	KLOX 185/65	KLOX 200/70	KLOX 220/80	KLOX 315/110	KLOX 315/110	KLOX 340/120	WLOX 1400 mm	WLOX 1600 mm	WLOX 2100 mm	WLOX 2300 mm	
	--	--	--	PMOF 200/70	PMOF 240/90	PMOF 240/90	PMOF 300/110	PMOF 300/110	PMOF 360/130	PMOF 470/170	PMOF 470/170	--	--	
Bell & Spigot (Tyton)	For WLOX, cut the sleeve to the circumference of the bell profile + 100mm. Approximate lengths are shown				PMO 170/80	PMO 200/100	PMO 200/100	PMO 260/160	PMO 310/195	PMO 380/230	PMO 425/265	--	--	
					WLOX 600 mm	WLOX 650 mm	WLOX 725 mm	WLOX 800 mm	WLOX 1000 mm	WLOX 1200 mm	WLOX 1350 mm	WLOX 1700 mm	WLOX 2000 mm	

Size Selection

Choose your sleeve based on Type of Joint and Pipe Dimensions

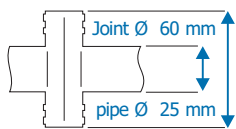

Example:
If the sleeve needs to protect a joint diameter of 60mm, and a pipe diameter of 25mm.
You would need a PMA 70/25

For pipe diameters > DN 500 (20"), consult your Canusa representative.

Typical Product Properties

Adhesive	Test Standard	Unit	PMO, KLOX, WLOX	PMOF	PMA	
			Softening Point	ASTM E28	°C	102
Lap Shear Strength	DIN 30 672 M	N/cm ²	40	30	60	
Backing	Tensile Strength	ASTM D638	MPa	24	24	24
	Elongation	ASTM D638	%	700	700	700
	Hardness	ASTM D2240	Shore D	48	48	48
	Dielectric Voltage Brkdwn.	ASTM D149	kV/mm	27	20	20
Sleeve	Peel	ASTM D1000	N/cm	80	70	50
	Peel	DIN 30 672	N/cm	65	60	35
	Cathodic Disbondment	ASTM G8	mm rad	8	13	13
	Water Absorption	ASTM D570	%	0.05	0.05	0.05
	Low Temp. Flexibility	ASTM D2671	°C	-14	-14	-32
	DIN Approval	DIN 30 672	class	C30	--	C50

Size Selection

Operating Characteristics

Operating Characteristics

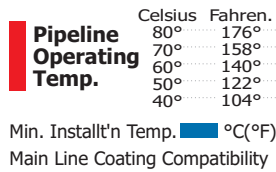

How To Order:

Product	Available Widths	Colours	Thickness*	Ordering Example
CanusaTube PMA <170mm Ø	100, 300, 500, 1000, 1500 mm (4", 12", 20", 40", 60")	BK - Black	3.2 mm (126 mils)	PMA-120/40-1500-BK
CanusaTube PMA >170mm Ø	300, 450, 600 mm (12", 18", 24")	BK - Black	3.8 mm (148 mils)	PMA-170/80-450-BK
CanusaTube PMO	300, 450, 600 mm (12", 18", 24")	BK - Black BL - Blue	3.2 mm (126 mils)	PMO-200/100-450-BK
CanusaTube PMOF	sleeve 300 mm (12") skirting 150mm(6")	BK - Black	2.5 mm (98 mils)	PMOF - 240/90-300-BK
CanusaTube KLOX	450, 600 mm (18", 24") 200mm(8")	BK - Black	5.9 mm (234 mils)	KLOX-220/80-300-BK
CanusaWrap WLOX	300, 450, 600, 900 mm (12", 18", 24", 36")	BK - Black BL - Blue	3.5 mm (138 mils)	WLOX-B-450-30-BK
CanusaWrap Closure Seal (with WLOX)	300, 450, 600, 900 mm (12", 18", 24", 36")	BK - Black	1.6 mm (62 mils)	CLH-115-450-BK or CLH-150-450-BK

* Fully Recovered Thickness



CANUSA-CPS

A SHAWCOR COMPANY

www.canusacps.com

Canada

CANUSA-CPS
a division of SHAWCOR LTD.
25 Bethridge Road
Rexdale, Ontario
M9W 1M7,
Canada
Tel: +1 (416) 743-7111
Fax: +1 (416) 743-5927

U.S.A./Latin America

CANUSA-CPS
a division of SHAWCOR INC.
2408 Timberloch Place
Building C-8
The Woodlands, Texas
77380, U.S.A.
Tel: +1 (281) 367-8866
Fax: +1 (281) 367-4304

Europe/Middle East

CANUSA-CPS
a division of Canusa Systems Ltd.
Unit 3, Sterling Park
Gatwick Road
Crawley, West Sussex
England RH10 9QT
Tel: +44 (1293) 541254
Fax: +44 (1293) 541777

Asia/Pacific

CANUSA-CPS
a division of SHAWCOR LTD.
#05-31, Blk 52, Frontier
Ubi Avenue 3
Singapore
408867
Tel: +65-6749-8918
Fax: +65-6749-8919